

AV09-4WL Solar Windsock Light Kit

Typical Applications

- ▶ Solar Windsock Light Kit

Major Benefits

- ▶ Integrated solar/battery system
- ▶ 120 watt solar module (standard)
- ▶ 96Ah SLA battery (standard)

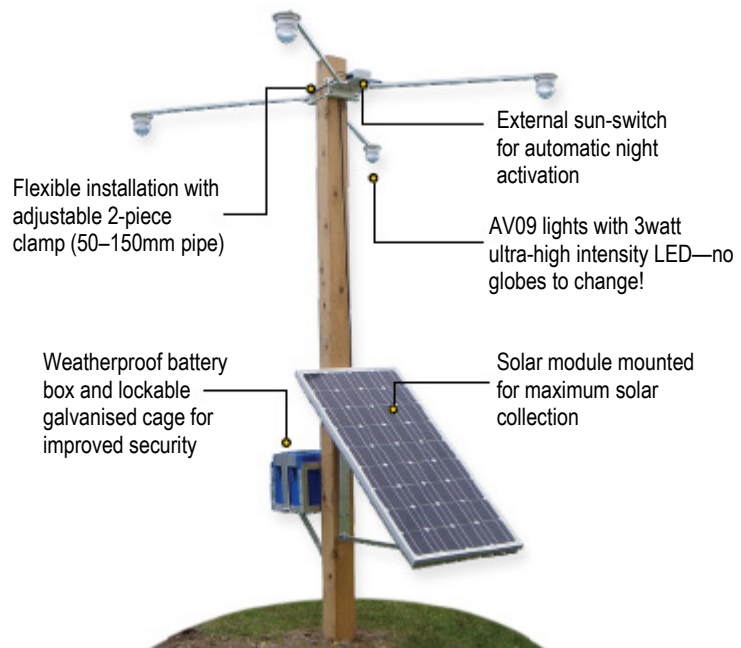

Avlite Systems' AV09-4WL Solar Windsock Light provides users with a complete, reliable and low maintenance solution to windsock illumination.

This complete windsock lighting kit incorporates four (4) AV09 lights mounted on to 12mm powder-coated square tubing arms, a 120 watt multicrystalline solar module and mounting bracket, and 96Ah SLA battery housed in a rotationally moulded weatherproof battery box with galvanized lockable cage for improved security.

Each AV09 light incorporates a 3 watt ultra-high intensity LED as a light source offering up to 100,000 hours of service— no need to change any globes! And with low power consumption and external sun-switch for automatic night activation, the AV09-4WL is a fantastic alternative to traditional hard-wired or fluorescent products.

The AV09-4WL can be installed immediately, facing either down over the top of the windsock, or upward from beneath and requires no costly underground wiring. The complete kit comes packaged in a 155x69x76cm pallet for ease of shipping—a complete unit ready for immediate installation!

Systems Interface Limited
Unit 71.5 Dunsfold Park
Cranleigh, Surrey, GU6 8TB
United Kingdom

Tel: +44(0)1483 267 066
www.systemsinterfaceltd.com



Total Turnkey Airport Solutions

AV09 Solar Windsock Light Kit

SPECIFICATIONS

Light Characteristics

Light Source	4 LED clusters in LEXAN® domed luminaires
Available Colours	White
Peak Intensity (cd)	>50
Vertical Divergence (degrees)	120
LED Life Expectancy (hours)	>100,000

Electrical Characteristics

Current Draw	1 amp
Circuit Protection	Polarity protected
Operating Voltage (v)	12
Autonomy (days)	8
Temperature Range	-40 to 80° C

Solar Characteristics

Solar Module Type	Multicrystalline
Output (watts)	120

Power Supply

Battery Type	SLA (Sealed Lead Acid)
Battery Capacity (Ah)	96
Nominal Voltage (v)	12

Certification

CE	EN61000-6-3:1977. EN61000-6-1:1997
Quality Assurance	ISO 9001:2000
Waterproof	IP68

Intellectual Property

Patents	US Pat.No.6.667.582.AU Pat.No.778.918
Trademarks	Avlite® is a registered trademark of Avlite Systems

Warranty

Full 3 year warranty

Options Available

GSM or radio remote activation

- Specifications subject to change or variation without notice

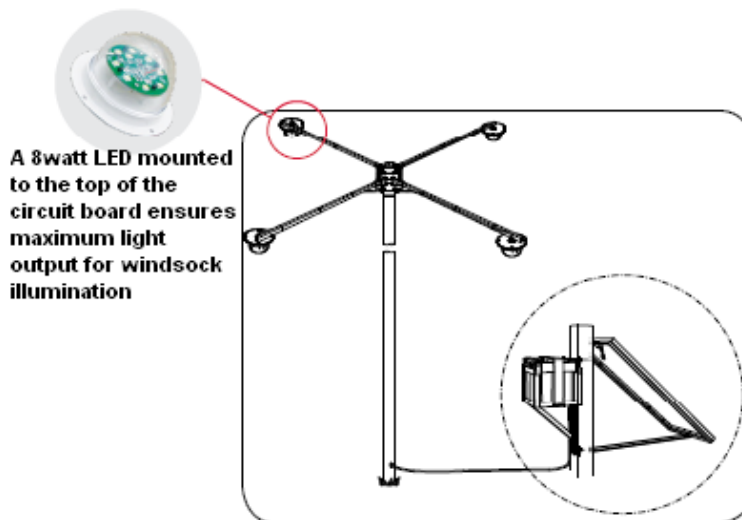

Systems Interface Limited
Unit 71.5 Dunsfold Park
Cranleigh, Surrey, GU6 8TB
United Kingdom

Tel: +44(0)1483 267 066
www.systemsinterfaceltd.com



Total Turnkey Airport Solutions

Available with GSM Monitoring

GSM enables operators to remotely monitor the status of their installations, and can be configured to send out warning SMS text messages to designated mobile telephone numbers.